

8 7 6 5 4 3 2 1

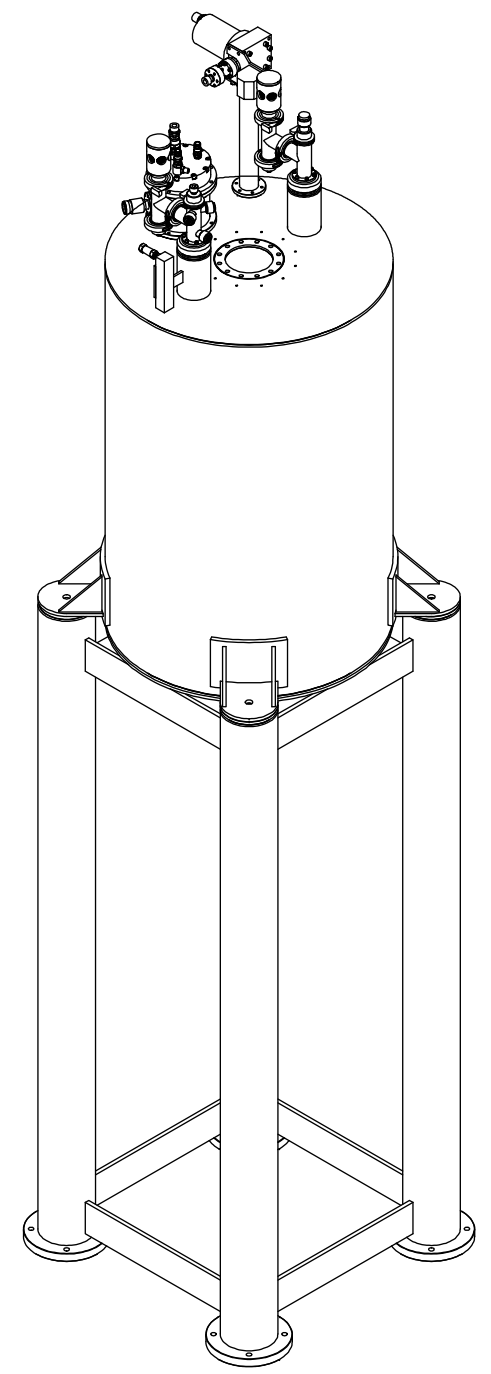

NOTES:
 1. DUE TO HEIGHT & WEIGHT OF THIS MAGNET, IT MUST BE BOLTED TO THE FLOOR.

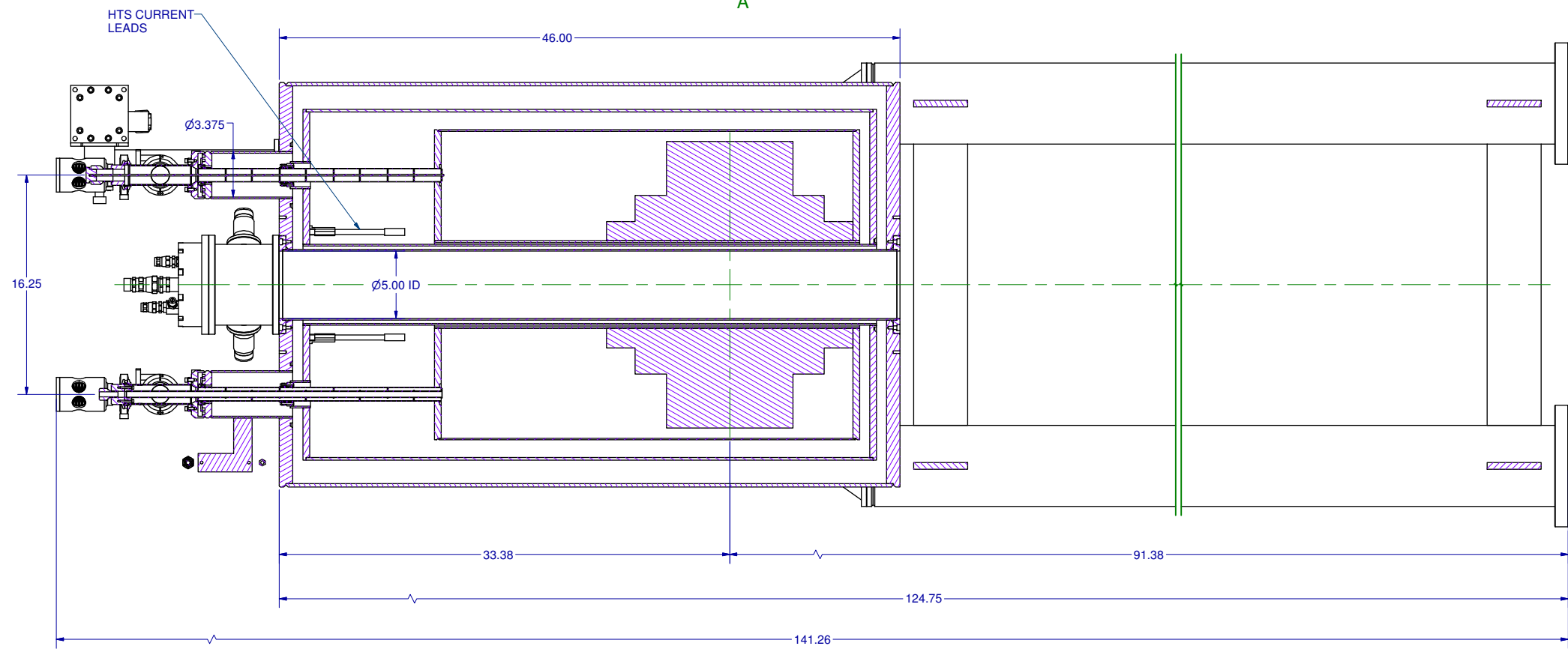
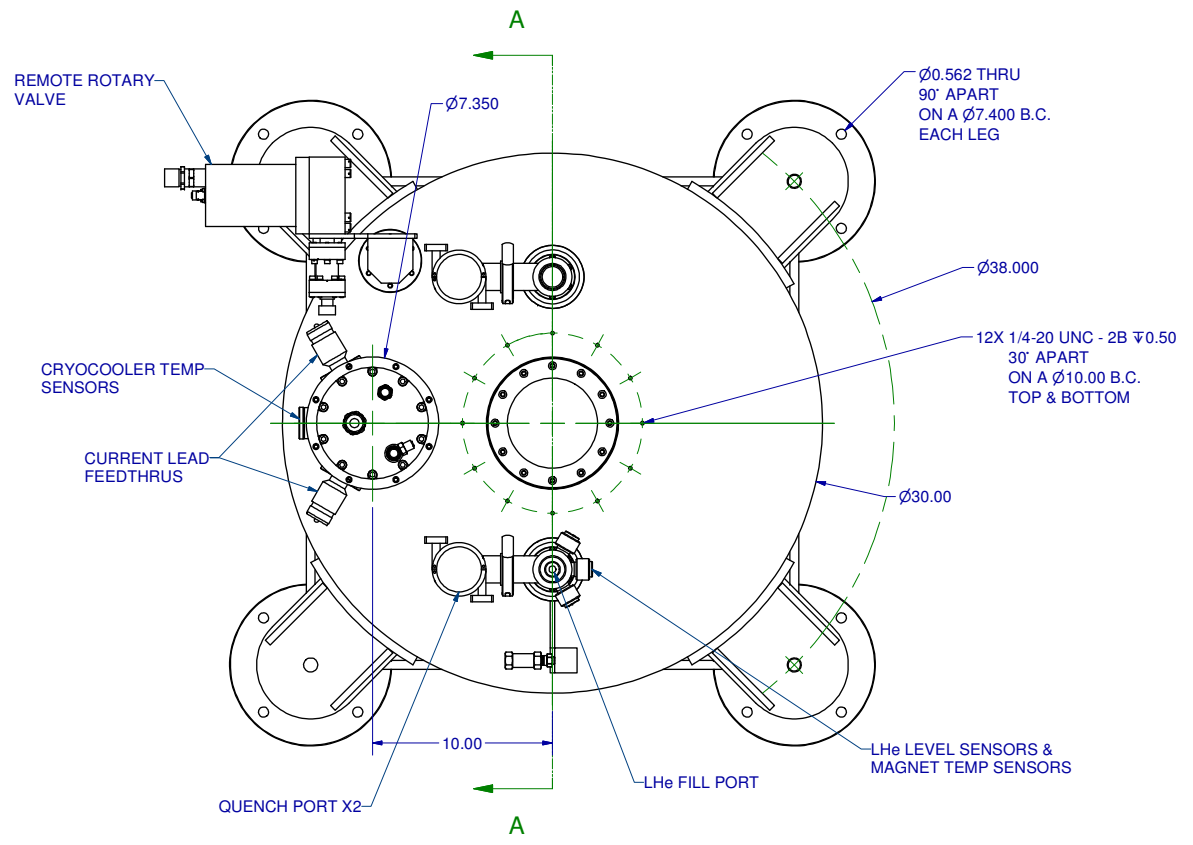

MATERIAL: FINISH: As Machined QUANTITY: 1	DO NOT SCALE UNLESS OTHERWISE INDICATED: TOLERANCES: 0.X - +/0.1 0.XXX - +/0.01 0.XXXX - +/0.005 ALL DIMENSIONS IN INCHES BREAK ALL EDGES	DRAWN Botello ENGINEER Berryhill CHECKED	2/13/2009 2/10/2009	Cryomagnetics, Inc. 1006 Alvin Weinberg Drive Oak Ridge, TN 37830 TITLE WO5572C Recondensing 14T Magnet System	SIZE D	DWG NO 5572C-C001	REV 0
	SCALE 3:16	SHEET 1 OF 1					

8 7 6 5 4 3 2 1